

Coupling

Parallelkey groove acc.to DIN6885

max.Ø25 / max.□22

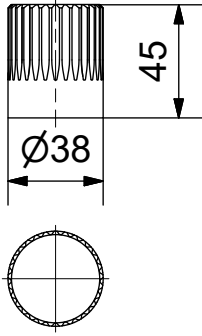

A-A (1 : 3)

Output Drive: F07, F10 acc. DIN5211

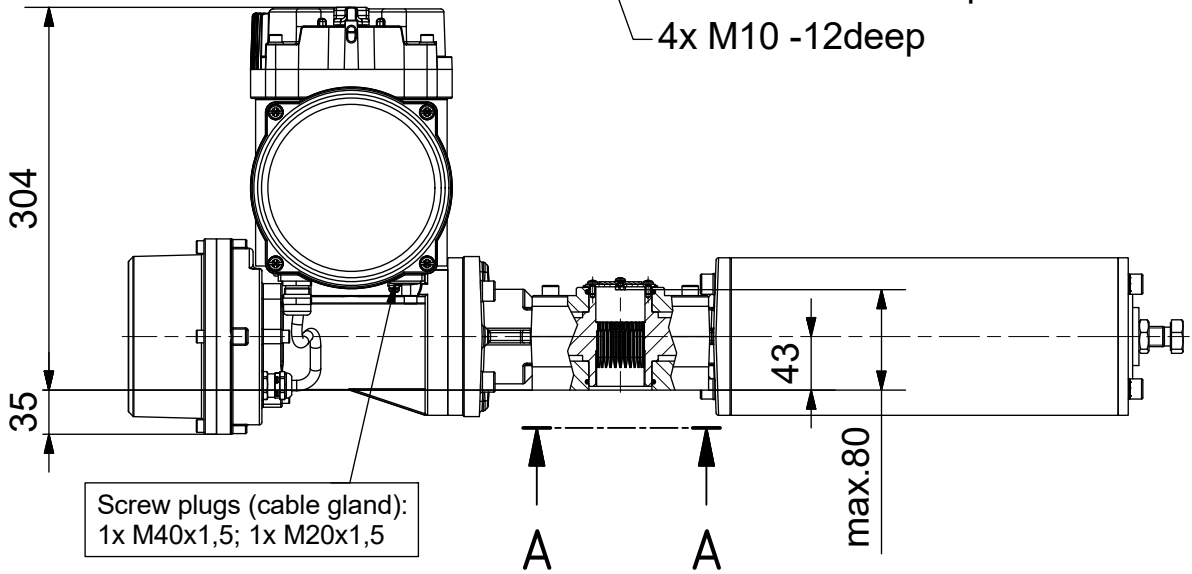
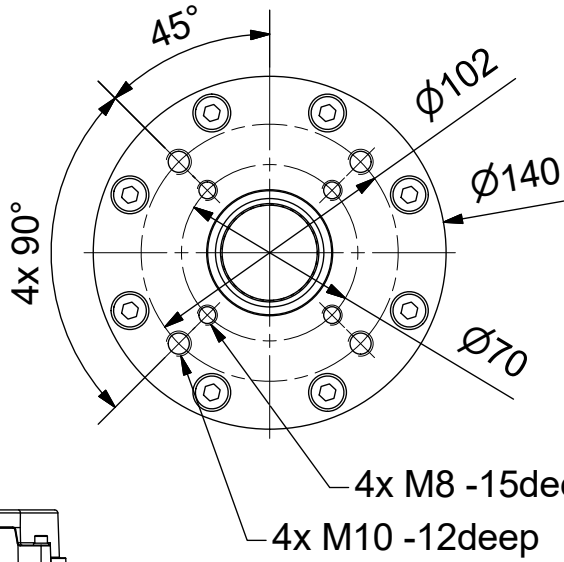

Screw plugs (cable gland):
1x M40x1,5; 1x M20x1,5

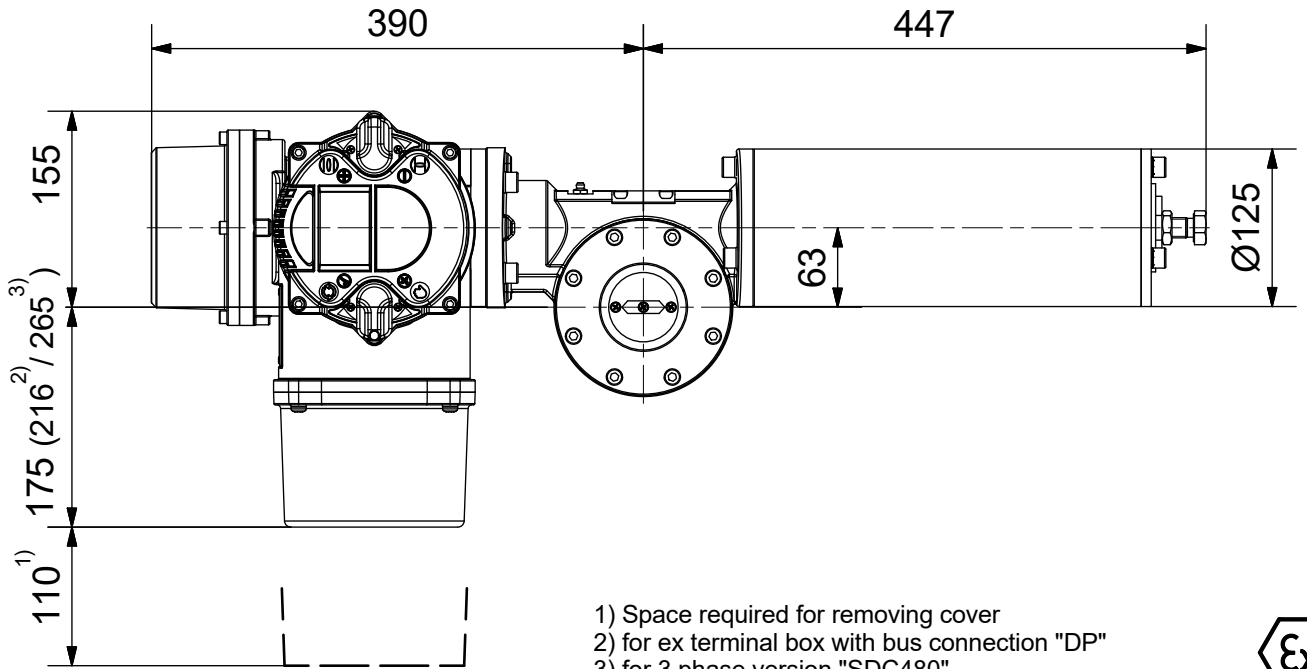

- 1) Space required for removing cover
- 2) for ex terminal box with bus connection "DP"
- 3) for 3 phase version "SDC480"



SCHIEBEL

Dimensions

All dimensions in mm

M-CM03FSQT30-20E

Actusafe 90°

exCM03FSQT30 F07+F10

Type: Failsafe CLOSE= cw turning, max. 300Nm

Antriebstechnik
Gesellschaft m.b.H.
Josef Benc Gasse 4
A - 1230 Vienna

	Dated	Name
drawn	12.04.2019	H.Mayer
checked		

