

Output Drive: F10, F12 acc. EN ISO 5211

A-A (1 : 3)

Coupling

Parallelkey groove acc.to DIN6885
max.Ø40 / max.□32 (directly Ø55/□45)

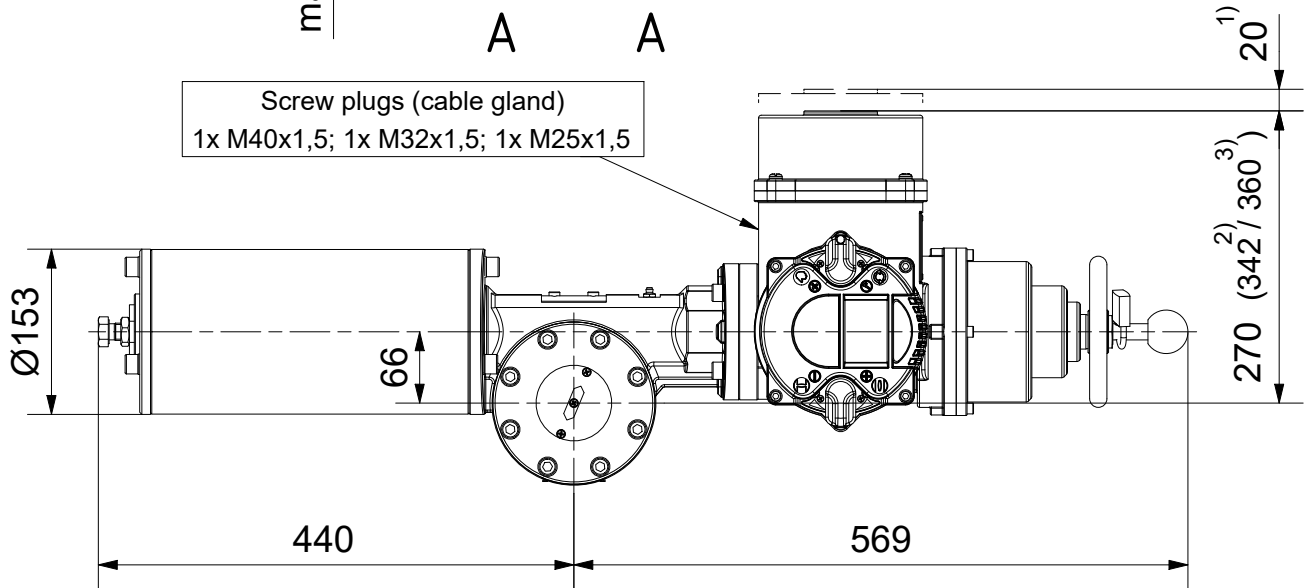
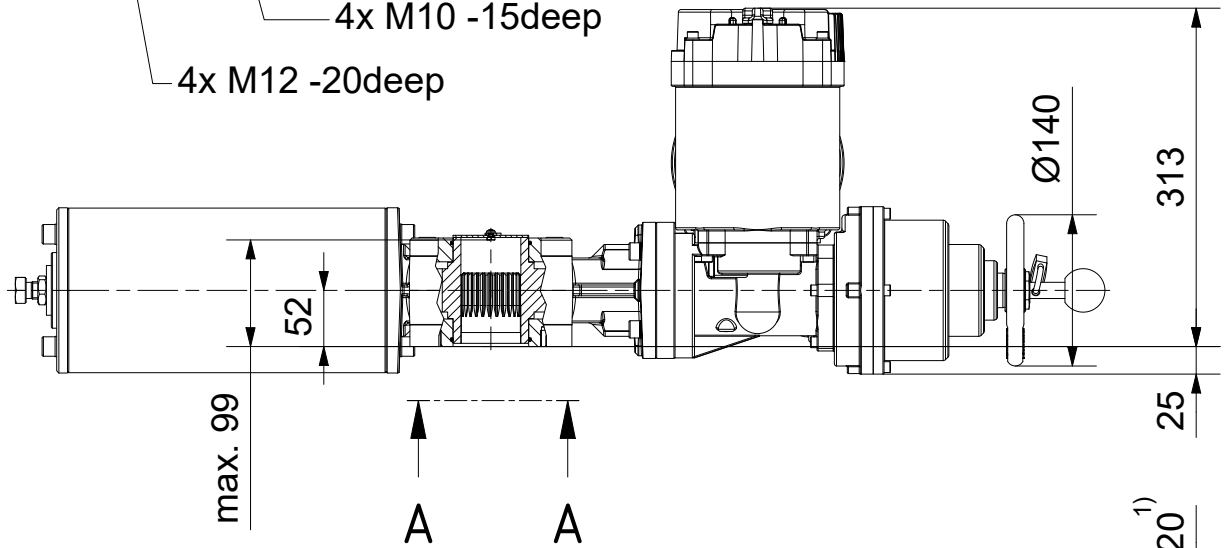
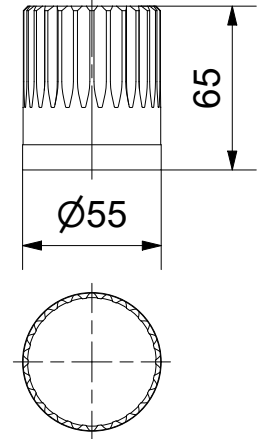
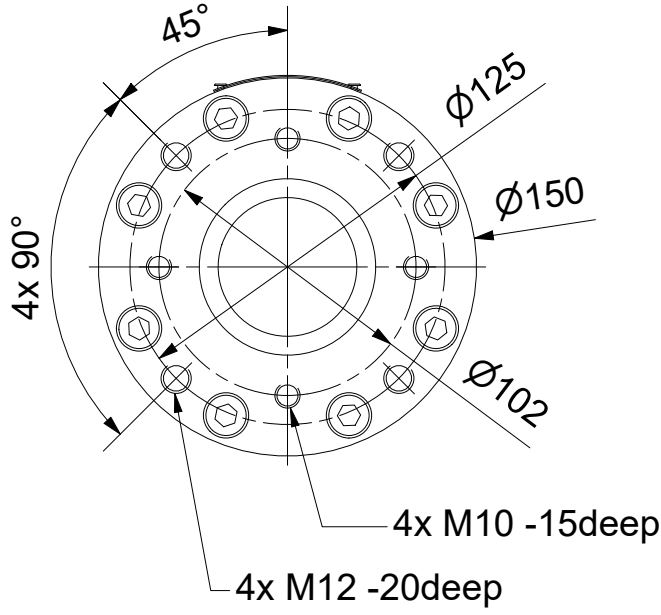

- 1) Space required for removing cover
- 2) for ex terminal box with bus connection "DP"
- 3) for 3 phase version "SDC480"

SCHIEBEL

Dimensions

All dimensions in mm

M-CM03FSQT60-23-1E

Actusafe 90° HA

CM03FSQT60 F10+F12

Type: Failsafe OPEN= ccw turning, 600Nm

Antriebstechnik
Gesellschaft m.b.H.
Josef Benc Gasse 4
A - 1230 Vienna

	Dated	Name
drawn	09.11.2017	H.Mayer
checked		

