

Coupling

Parallel key groove acc.to DIN6885

max.Ø60 / max.□48

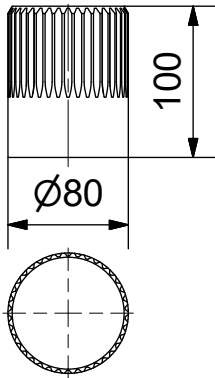

Output Drive: F14, F16 acc. DIN5211

A-A (1 : 7)

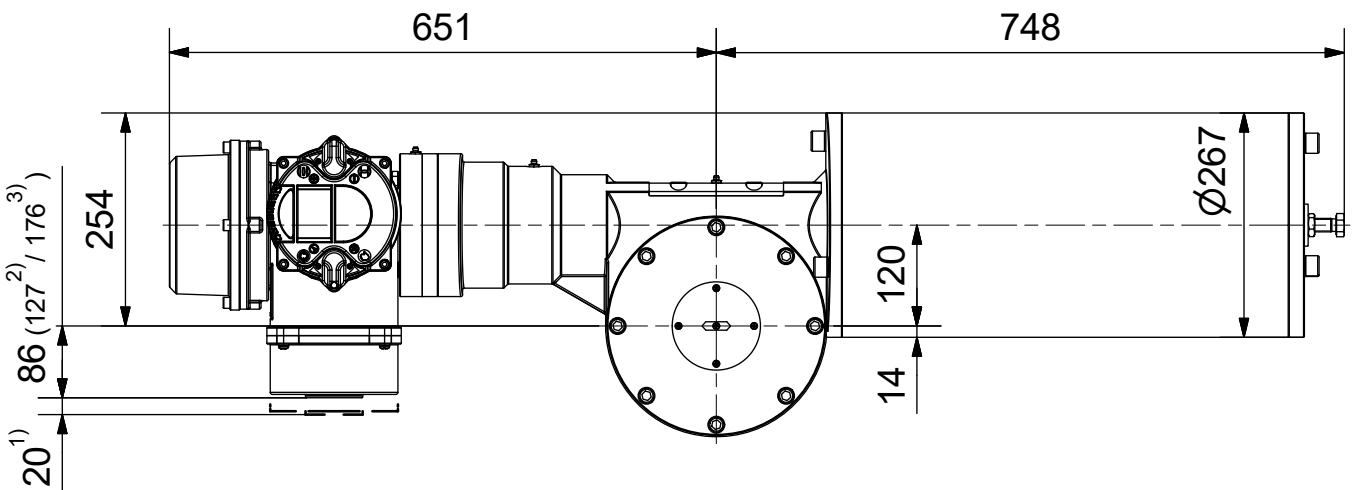
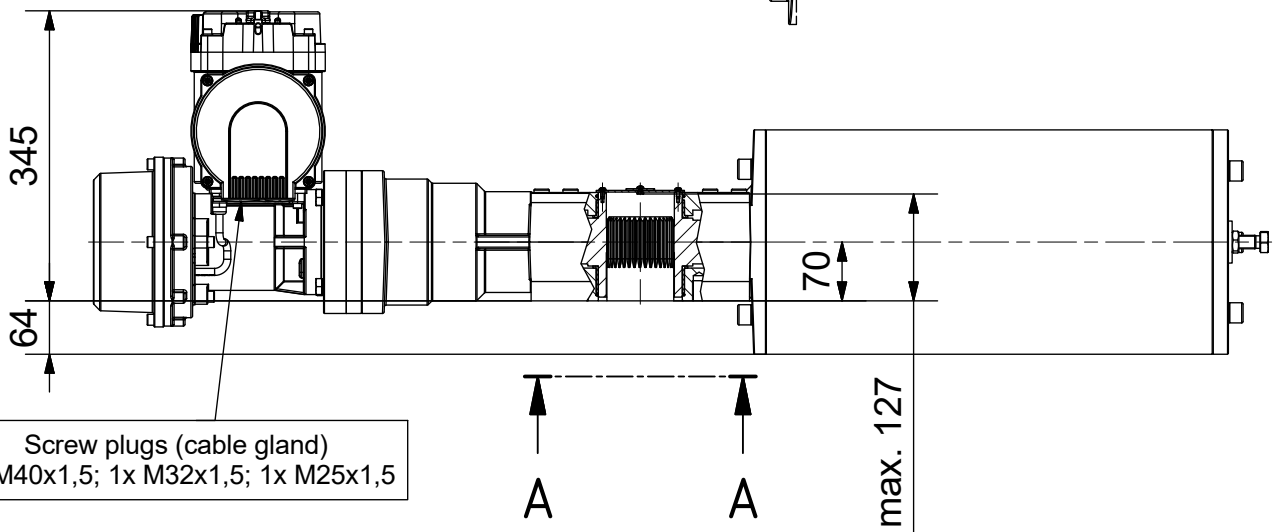
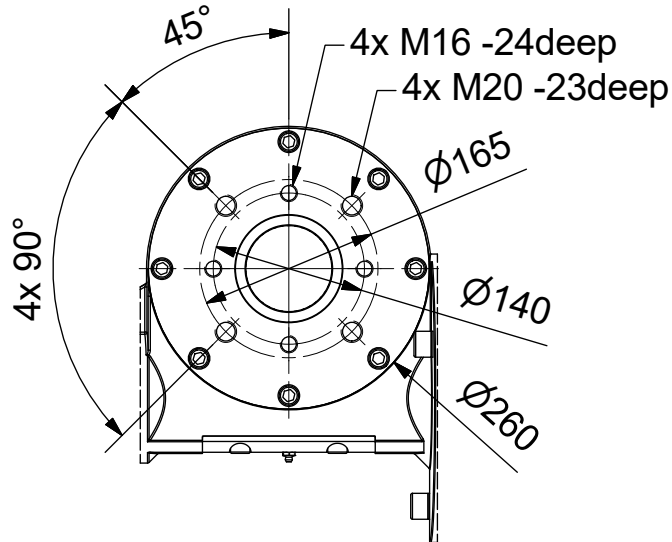

- 1) Space required for removing cover
- 2) for ex terminal box with bus connection "DP"
- 3) for 3 phase version "SDC480"

SCHIEBEL

Dimensions

All dimensions in mm

M-CM06FSQT300-22E

Actusafe 90°

CM06FSQT300 F14+F16

Type: Failsafe CLOSE= cw turning, max. 3000Nm

Antriebstechnik
Gesellschaft m.b.H.
Josef Benc Gasse 4
A - 1230 Vienna

	Dated	Name
drawn	25.01.2018	H.Mayer
checked		

