

Output Drive: F14, F16 acc. DIN5211

Coupling

Parallelkey groove acc.to DIN6885
max.Ø60 / max.□48 (directly Ø80/□63)

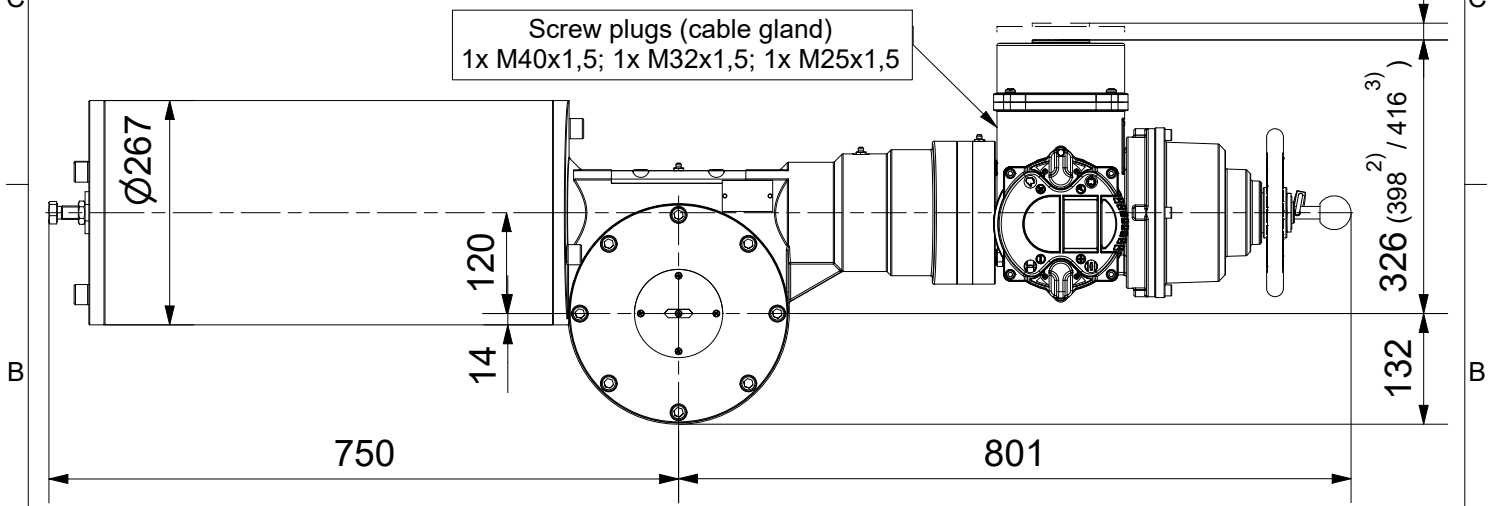
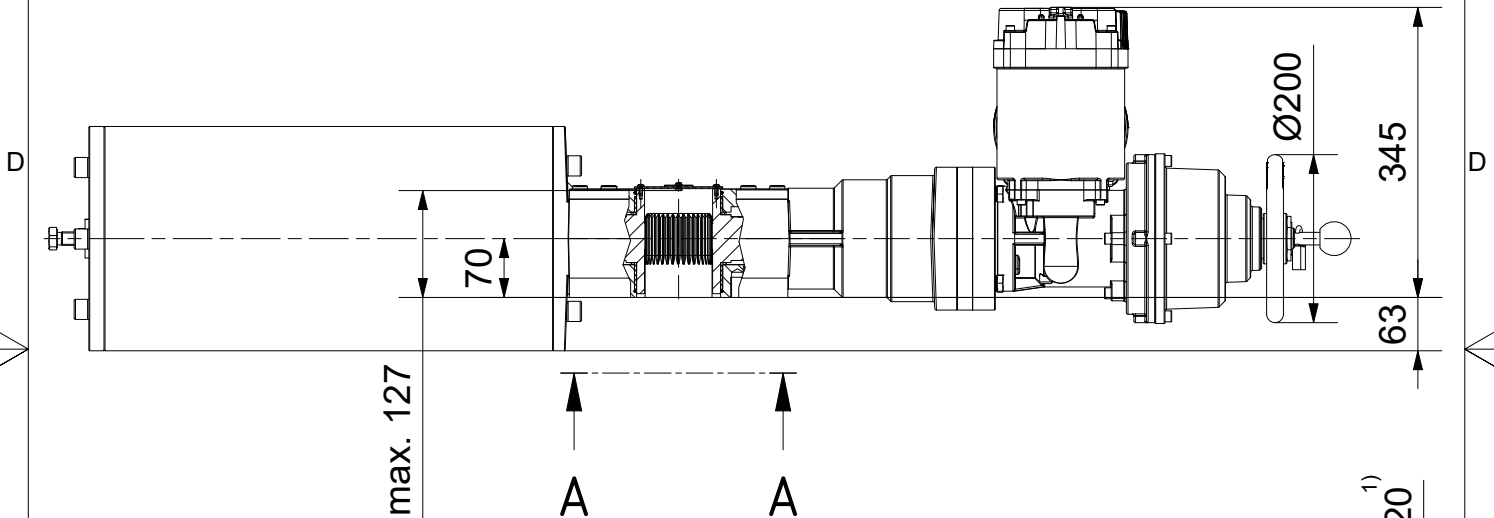
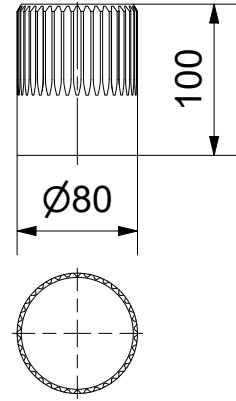
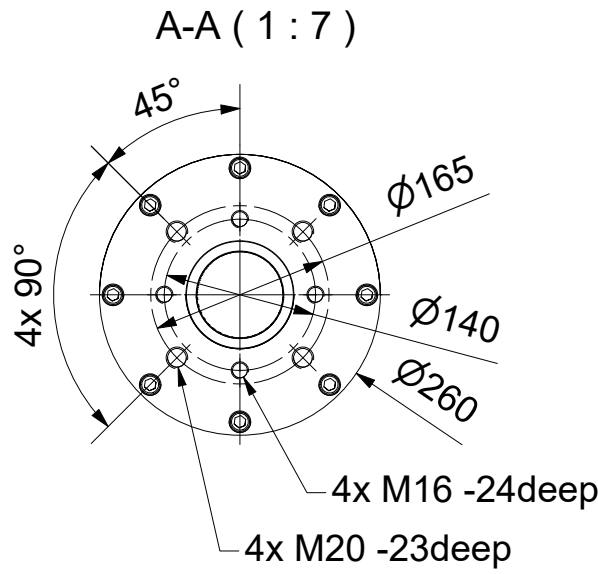

- 1) Space required for removing cover
- 2) for terminal box with bus connection "DP"
- 3) for 3 phase version "SDC480"

SCHIEBEL

Dimensions

All dimensions in mm

M-CM06FSQT300-23-1E

Actusafe 90°

CM06FSQT300 with handwheel, F14+F16
Type: Failsafe OPEN= ccw turning, 3000Nm

	Dated	Name
drawn	25.01.2018	H.Mayer
checked		

